



ENZO FORNI

SERIES: NAPOLI SERIES

110-120-130-140 GAS

THE ORIGINAL NEAPOLITAN PIZZA OVEN

Since 2010, we have been creating the best pizza ovens. More than a decade of craftsmanship in the construction of stoves is reflected in every ENZO FORNI brick stove. Approved by the Accademia Maestri Pizzaioli, this is the oven to prepare authentic Neapolitan pizza.



FEATURES

The ENZO FORNI Circolare series ovens are hand-built Neapolitan brick ovens which feature a cast steel door opening 420 mm or 520 mm wide by 210 mm high. The refractory baking floor diameter ranges from 800mm up to 1400 mm, lined with hand-made clay bricks to form a dome. An internal steel and cement structure reinforces the dome and shapes the oven base. A proprietary mixture of Neapolitan sand, volcanic rock and clay form a thick insulation, ensuring heat retention.

SPECIFICATIONS

- Plain of cooking: Biscotto di Sorrento, Biscotto EF,
- Crown and dome: Refractory bricks 60 mm. thick, temperature resistance over 900 °C
- Support stand: Reinforced and painted iron structure (four legs)
- External covering: Mosaic tiles - palladiana marble
- Electronic burner with two modulating flames max thermal capacity kW 34 - kcal/h 29.200
- Temperature range of working: 0 °C - 500 °C
- Electronic unit control for temperature management
- Alimentation: Gas
- Gas consumption at max. temperature
- Natural gas: 3,50 Nmc/h
- LPG: 1,22 Nmc/h
- Flue output: Ø 160 - 250 mm.
- Max heat output: 29.200 kcal - 34 kW

Outside temperature at work: 37°

Available in 3 options:





GASPARE SERIES

SERIES: NAPOLI SERIES

110-120-130-140 GAS

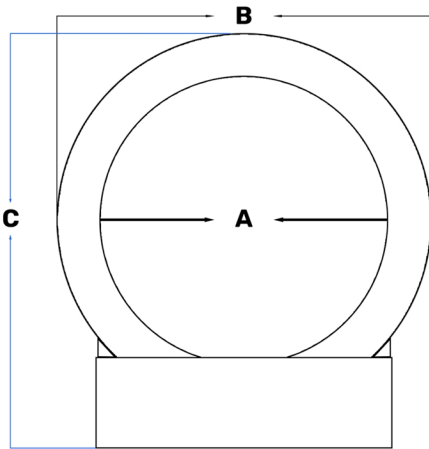

MODEL	NO. PIZZAS	SIZES	HEIGHT	WEIGHT
M110	4	A:110, B:160, C:180	195	1700
M120	5	A:120, B:170, C:190	195	2100
M130	6	A:130, B:180, C:200	195	2500
M140	7	A:140, B:190, C:210	195	2800
Untypical oven		Special size - Project		



Recommended baking time:
90 - 120 seconds

Perfect for pizza napoletana,
classica, artisan pizza, chicago



**Recommended oven floor
temperature range: 390°C - 480°C**



Daily preheat time:
25-60 minutes

DESCRIPTION

Technology that allows a high degree of heat retention with consequent energy savings. Our "heat tank" saves up to 85% in fuel.

We only use high innovation products used in the high technology sector.

GASPARE professional ovens are completely made by hand, according to the ancient tradition of pizza oven construction.

This series has the best heat accumulation coefficient among the pizza ovens available on the market.

Enzo Forni

Nowy Swiat 26 St, 41-706 Ruda Slaska, Poland

Email: office@enzoforni.eu

(0048) 539 367 341

www.enzoforni.eu



FENICE SERIES

SERIES: NAPOLI SERIES
110-120-130-140 GAS

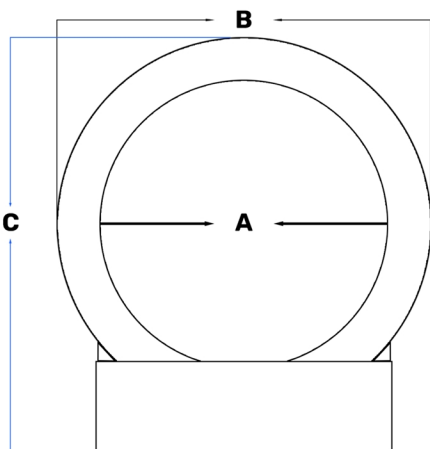

MODEL	NO. PIZZAS	SIZES	HEIGHT	WEIGHT
M110	4	A:110, B:170, C:185	205	1900
M120	5	A:120, B:185, C:195	209	2100
M130	6	A:130, B:195, C:205	213	2200
M140	7	A:140, B:200, C:215	215	2400
Untypical oven		Special size - Project		



Recommended baking time:
90 - 120 seconds

Perfect for pizza napoletana,
classica, artisan pizza, chicago



**Recommended oven floor
temperature range: 390°C - 480°C**



Daily preheat time:
25-60 minutes

DESCRIPTION

Technology that allows a high degree of heat retention with consequent energy savings. Our "heat tank" saves up to 70% in fuel.

We only use natural and environmentally sustainable products, in accordance with the principles of the circular economy, thanks to the reintroduction of recovered materials from the same production waste into the various processing stages.

FENICE professional ovens are completely made by hand, according to the ancient tradition of pizza oven construction.

Enzo Forni

Nowy Swiat 26 St, 41-706 Ruda Slaska, Poland

Email: office@enzoforni.eu

(0048) 539 367 341

www.enzoforni.eu



STANDARD SERIES

SERIES: NAPOLI SERIES

110-120-130-140 GAS

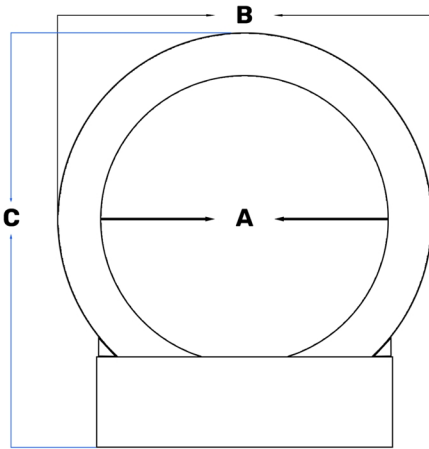

MODEL	NO. PIZZAS	SIZES	HEIGHT	WEIGHT
M110	4	A:110, B:140, C:165	205	1900
M120	5	A:120, B:150, C:175	209	2200
M130	6	A:130, B:160, C:185	213	2500
M140	7	A:140, B:170, C:195	215	2800
Untypical oven		Special size - Project		



Recommended baking time:
90 - 120 seconds

Perfect for pizza napoletana,
classica, artisan pizza, chicago



**Recommended oven floor
temperature range: 390°C - 480°C**



Daily preheat time:
25-60 minutes

DESCRIPTION

Technology that allows a high degree of heat retention with consequent energy savings. Our "heat tank" saves up to 75% in fuel.

We mixing professional refractory technology materials with natural and environmentally sustainable products, in accordance with the principles of the circular economy, thanks to the reintroduction of recovered materials from the same production waste into the various processing stages.

STANDARD series are completely made by hand, according to the ancient tradition of pizza oven construction.

Enzo Forni

Nowy Swiat 26 St, 41-706 Ruda Slaska, Poland

Email: office@enzoforni.eu

(0048) 539 367 341

www.enzoforni.eu