



ENZO FORNI

SERIES: CIRCOLARE 80-90 SERIES
GAS ALIMENTATION

THE ORIGINAL NEAPOLITAN PIZZA OVEN

Since 2010, we have been creating the best pizza ovens. More than a decade of craftsmanship in the construction of stoves is reflected in every ENZO FORNI brick stove. Approved by the Accademia Maestri Pizzaioli, this is the oven to prepare authentic Neapolitan pizza.



FEATURES

The ENZO FORNI Circolare series ovens are hand-built Neapolitan brick ovens which feature a cast steel door opening 420 mm or 520 mm wide by 210 mm high. The refractory baking floor diameter ranges from 800mm up to 1400 mm, lined with hand-made clay bricks to form a dome. An internal steel and cement structure reinforces the dome and shapes the oven base. A proprietary mixture of Neapolitan sand, volcanic rock and clay form a thick insulation, ensuring heat retention.

SPECIFICATIONS

- Plain of cooking: Biscotto di Sorrento
 - Crown and dome: Refractory bricks 60 mm. thick, temperature resistance over 900 °C
 - Support stand: Reinforced and painted iron structure (four legs)
 - External covering: Mosaic tiles – palladiana marble
 - Electronic burner with one modulating flame max thermal capacity kW 24 – kcal/h 20.640
 - Temperature range of working: 0 °C – 500 °C
 - Electronic unit control for temperature management
 - Alimentation: Gas
 - Gas consumption at max. temperature:
 - Natural gas: 2,54 Nmc/h
 - LPG : 0,86 Nmc/h
 - Flue output: Ø 160 - 250 mm.
 - Max heat output: 20.640 kcal – 24 kW
 - Smokes temperature output: 190 °C
 - Extract air flow: 650 mc/h (at starting)
 - 500 mc/h (at full operating)
 - Required CFM: 380
 - Venting: Natural draft
 - Electrical supply: 230 V – 50/60 Hz one phase
 - Electrical absorption: 100 Watt
 - Gas connection: ½ inch
- Gas pressure:
 - Natural gas: from 15 mbar - to 25 mbar
 - LPG: from 25 mbar - to 50 mbar
 - It's required a direct connection of the tube that serves the oven from gas meter to the oven no other equipment must be installed on the same line between the meter and the oven.
 - For the gas line use the follows pipes size:
 - Distance from the gas meter to the oven until 10 meters (32 ft) use:
 - For LPG ½" pipe
 - For Natural gas ¾" pipe
 - Distance from the gas meter to the oven over 10 meters (32 ft) use 1" pipe (independently to the gas in use)

Outside temperature at work: 37°

Available in 3 options:





GASPARE SERIES

SERIES: CIRCOLARE 80-90 SERIES
GAS ALIMENTATION

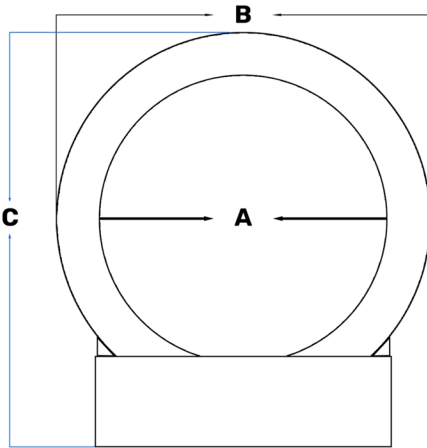

MODEL	NO. PIZZAS	SIZES	HEIGHT	WEIGHT
M80	2	A:80, B:135, C:155	195	980
M90	3	A:90, B:145, C:165	195	1300
Untypical oven		Special size - Project		



Recommended baking time:
90 - 120 seconds

Perfect for pizza napoletana,
classica, artisan pizza, chicago



**Recommended oven floor
temperature range: 390°C - 480°C**



Daily preheat time:
25-60 minutes

DESCRIPTION

Technology that allows a high degree of heat retention with consequent energy savings. Our "heat tank" saves up to 85% in fuel.

We only use high innovation products used in the high technology sector.

GASPARE professional ovens are completely made by hand, according to the ancient tradition of pizza oven construction.

This series has the best heat accumulation coefficient among the pizza ovens available on the market.

Enzo Forni

Nowy Swiat 26 St, 41-706 Ruda Slaska, Poland

Email: office@enzoforni.eu

(0048) 539 367 341

www.enzoforni.eu



FENICE SERIES

SERIES: CIRCOLARE 80-90 SERIES
GAS ALIMENTATION

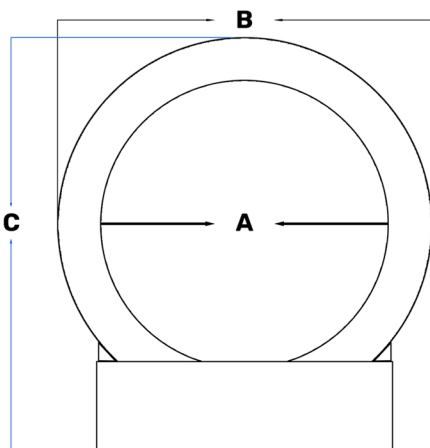

MODEL	NO. PIZZAS	SIZES	HEIGHT	WEIGHT
M80	2	A:80, B:130, C:155	204	900
M90	3	A:90, B:140, C:165	205	1200
Untypical oven		Special size - Project		



Recommended baking time:
90 - 120 seconds

Perfect for pizza napoletana,
classica, artisan pizza, chicago



**Recommended oven floor
temperature range:** 390°C - 480°C



Daily preheat time:
25-60 minutes

DESCRIPTION

Technology that allows a high degree of heat retention with consequent energy savings. Our "heat tank" saves up to 70% in fuel.

We only use natural and environmentally sustainable products, in accordance with the principles of the circular economy, thanks to the reintroduction of recovered materials from the same production waste into the various processing stages.

FENICE professional ovens are completely made by hand, according to the ancient tradition of pizza oven construction.

Enzo Forni

Nowy Swiat 26 St, 41-706 Ruda Slaska, Poland

Email: office@enzoforni.eu

(0048) 539 367 341

www.enzoforni.eu



STANDARD SERIES

SERIES: CIRCOLARE 80-90 SERIES
GAS ALIMENTATION

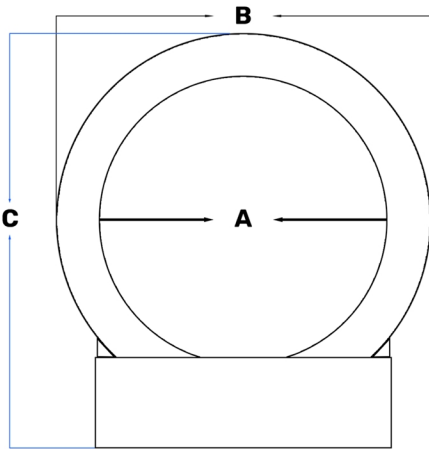

MODEL	NO. PIZZAS	SIZES	HEIGHT	WEIGHT
M80	2	A:80, B:110, C:135	204	1500
M90	3	A:90, B:120, C:145	205	1700
Untypical oven		Special size - Project		



Recommended baking time:
90 - 120 seconds

Perfect for pizza napoletana,
classica, artisan pizza, chicago



Recommended oven floor
temperature range: 390°C - 480°C



Daily preheat time:
25-60 minutes

DESCRIPTION

Technology that allows a high degree of heat retention with consequent energy savings. Our "heat tank" saves up to 75% in fuel.

We mixing professional refractory technology materials with natural and environmentally sustainable products, in accordance with the principles of the circular economy, thanks to the reintroduction of recovered materials from the same production waste into the various processing stages.

STANDARD series are completely made by hand, according to the ancient tradition of pizza oven construction.

Enzo Forni

Nowy Swiat 26 St, 41-706 Ruda Slaska, Poland

Email: office@enzoforni.eu

(0048) 539 367 341

www.enzoforni.eu